



GRAFFE - APPLICAZIONI INDUSTRIALI STAPLES - INDUSTRIAL APPLICATIONS

Leggere / Fine wire
Medie / Medium wire
Pesanti / Heavy wire

**GRAFFE LEGGERE
FINE WIRE STAPLES**

3G

Serie chiodatrice Nails series	modello	misure impiegabili (mm)	capacità caricatore (n.punti)	pressione (kg/cm ²)	peso (kg)	consumo aria (litri/colpo)	dimensioni (mm - L x W x H)
	model	applicable sizes (inch)	magazine capacity (pieces)	pressure (PSI)	weight (lbs)	air consumption (ft ³ /cycle)	dimensions (inch - L x W x H)

**UTILIZZI
APPLICATIONS**

Tappezzeria, produzione di mobili, cornici, calzature, fodere, set TV o stereo, isolamento delle case, isolamento in feltro, produzione di dorsi di casse, finiture interne in legno.

Upholstery, furniture, picture frames, shoe making, dust covers, TV or stereo sets, home insulation, felt insulation, casebacks production, trimming.



3G



Versione V - V model

100	3G	4 ÷ 14	175	3,5 ÷ 6	0,60	0,10	200 x 33 x 141
		5/32" ÷ 9/16"	175	50 ÷ 90	1,32	0,00353	7-7/8" x 1-5/16" x 5-9/16"
	3GV	4 ÷ 14	175	4 ÷ 6	0,60	0,10	200 x 33 x 141
		5/32" ÷ 9/16"	175	60 ÷ 90	1,32	0,00353	7-7/8" x 1-5/16" x 5-9/16"



3G.16



Versione H - H model



Versione SL - SL model



Versione V - V model

**SPECIFICHE
SPECIFICATIONS**

Punti per barretta 167
Staples per strip 167

Finitura zincato
Finishing galvanvanized

A richiesta inox,
alluminio,
DP (punte
divergenti)

On request stainless steel,
aluminium,
DP (divergent
point)

MINI	3G.16	4 ÷ 16	185	4 ÷ 6	0,90	0,13	216 x 43 x 148
		5/32" ÷ 5/8"	185	60 ÷ 90	1,98	0,00459	8-1/2" x 1-11/16" x 5-13/16"
	3G.16 H	4 ÷ 16	185	4 ÷ 6	0,90	0,13	216 x 43 x 148
		5/32" ÷ 5/8"	185	60 ÷ 90	1,98	0,00459	8-1/2" x 1-11/16" x 5-13/16"
	3G.16 SL	4 ÷ 16	185	4 ÷ 6	1,00	0,18	216 x 43 x 198
		5/32" ÷ 5/8"	185	60 ÷ 90	2,20	0,00636	8-1/2" x 1-11/16" x 7-13/16"
	3G.16 V	4 ÷ 16	185	4 ÷ 6	0,95	0,13	216 x 43 x 148
		5/32" ÷ 5/8"	185	60 ÷ 90	2,09	0,00459	8-1/2" x 1-11/16" x 5-13/16"



3G.16 CL



Versione V - V model

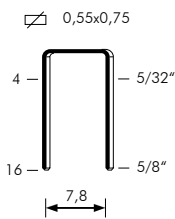

Gauge: 23
Crown: .350" (3/8")

MINI	3G.16 CL	4 ÷ 16	360	4 ÷ 6	1,10	0,13	350 x 43 x 148
		5/32" ÷ 5/8"	360	60 ÷ 90	2,43	0,00459	13-13/16" x 1-11/16" x 5-13/16"
	3G.16 CLV	4 ÷ 16	360	4 ÷ 6	1,15	0,13	350 x 43 x 148
		5/32" ÷ 5/8"	360	60 ÷ 90	2,54	0,00459	13-13/16" x 1-11/16" x 5-13/16"



3G.16 CLT

MINI	3G.16 CLT	4 ÷ 16	340	4 ÷ 6	1,10	0,13	362 x 43 x 148
		5/32" ÷ 5/8"	340	60 ÷ 90	2,43	0,00459	14-1/4" x 1-11/16" x 5-13/16"

Serie chiodatrice EOL SERIES	modello	misure impiegabili (mm)	capacità caricatore (n.punti)	pressione (kg/cm ²)	peso (kg)	consumo aria (litri/colpo)	dimensioni (mm - L x W x H)
	model	applicable sizes (inch)	magazine capacity (pieces)	pressure (PSI)	weight (lbs)	air consumption (l/cycle)	dimensions (inch - L x W x H)

GRAFFE LEGGERE
FINE WIRE STAPLES

68



68.16



Versione H - H model



Versione SL - SL model



Versione V - V model

UTILIZZI APPLICATIONS

Tappezzeria, produzione di mobili, isolamento in feltro, finiture interne in legno.

Upholstery, production of furniture, felt insulation, trimming.

SPECIFICHE SPECIFICATIONS

Punti per barretta Staples per strip	167 167
Finitura Finishing	zincato galvanized
A richiesta On request	inox stainless steel

MINI	68.16	4 ÷ 16 5/32" ÷ 5/8"	185	4 ÷ 6 60 ÷ 90	0,90 1,98	0,13 0,00459	216 x 43 x 148 8-1/2" x 1-11/16" x 5-13/16"
		68.16 H	4 ÷ 16 5/32" ÷ 5/8"	185	4 ÷ 6 60 ÷ 90	0,90 1,98	0,13 0,00459
	68.16 SL	4 ÷ 16 5/32" ÷ 5/8"	185	4 ÷ 6 60 ÷ 90	1,00 2,20	0,18 0,00636	216 x 43 x 198 8-1/2" x 1-11/16" x 7-13/16"
	68.16 V	4 ÷ 16 5/32" ÷ 5/8"	185	4 ÷ 6 60 ÷ 90	0,95 2,09	0,13 0,00459	216 x 43 x 148 8-1/2" x 1-11/16" x 5-13/16"

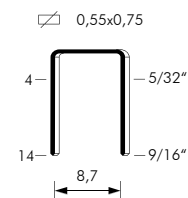

Gauge: 23
Crown: .386" (3/8")

GRAFFE LEGGERE
FINE WIRE STAPLES

SJK

Serie chiodatrice Tool series	modello	misure impiegabili (mm)	capacità caricatore (n.punti)	pressione (kg/cm ²)	peso (kg)	consumo aria (litri/colpo)	dimensioni (mm - L x W x H)
	model	applicable sizes (inch)	magazine capacity (pieces)	pressure (PSI)	weight (lbs)	air consumption (ft ³ /cycle)	dimensions (inch - L x W x H)



SJK.16

UTILIZZI
APPLICATIONS

Tappezzeria, produzione di calzature, mobili da giardino, ombrelli e spazzole.

Upholstery, shoe making, garden furniture, umbrellas and brushes.

MINI	SJK.16	4 ÷ 16 5/32" + 5/8"	170	4 ÷ 6 60 ÷ 90	0,90 1,98	0,13 0,00459	216 x 43 x 148 8-1/2" x 1-11/16" x 5-13/16"
------	--------	------------------------	-----	------------------	--------------	-----------------	--

SPECIFICHE
SPECIFICATIONS

Punti per barretta 167
Staples per strip 167

Finitura zincato
Finishing galvanized

A richiesta inox
On request stainless steel



SJK.16 CLM



SJK.16 CLM MINI-REST

MINI	SJK.16 CLM	8 ÷ 16 5/16" + 5/8"	340	4 ÷ 6 60 ÷ 90	1,07 2,36	0,13 0,00459	362 x 43 x 148 14-1/4" x 1-11/16" x 5-13/16"
	SJK.16 CLM MINI-REST	8 ÷ 16 5/16" + 5/8"	340	4 ÷ 6 60 ÷ 90	7,10 15,66	0,13 0,00459	370 x 170 x 425 14-9/16" x 6-11/16" x 16-3/4"

0,55x0,75

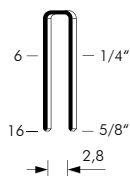

Gauge: 23
Crown: .154" (5/32")



SJK.16 CLT

MINI	SJK.16 CLT	4 ÷ 16 5/32" + 5/8"	340	4 ÷ 6 60 ÷ 90	1,07 2,36	0,13 0,00459	362 x 43 x 148 14-1/4" x 1-11/16" x 5-13/16"
------	------------	------------------------	-----	------------------	--------------	-----------------	---

Serie Modulare E.O. SERIES	modello	misure impiegabili (mm)	capacità caricatore (n.punti)	pressione (kg/cm ²)	peso (kg)	consumo aria (litri/colpo)	dimensioni (mm - L x W x H)
	model	applicable sizes (inch)	magazine capacity (pieces)	pressure (PSI)	weight (lbs)	air consumption (l/cycle)	dimensions (inch - L x W x H)

GRAFFE LEGGERE FINE WIRE STAPLES

64



64.16



Versione SL - SL model



Versione V - V model

MINI	64.16	4 ÷ 16 5/32" ÷ 5/8"	185	4 ÷ 6 60 ÷ 90	0,90 1,98	0,13 0,00459	216 x 43 x 148 8-1/2" x 1-11/16" x 5-13/16"
	64.16 SL	4 ÷ 16 5/32" ÷ 5/8"	185	4 ÷ 6 60 ÷ 90	1,00 2,20	0,18 0,00636	216 x 43 x 198 8-1/2" x 1-11/16" x 7-13/16"
64.16 V	4 ÷ 16	185	4 ÷ 6	0,95	0,13	216 x 43 x 148	
	5/32" ÷ 5/8"	185	60 ÷ 90	2,09	0,00459	8-1/2" x 1-11/16" x 5-13/16"	

UTILIZZI APPLICATIONS

Tappezzeria, produzione di mobili, cornici, calzature, fodere, set TV o stereo, isolamento delle case, isolamento in feltro, produzione di dorsi di casse, finiture interne in legno.

Upholstery, furniture, picture frames, shoe making, dust covers, TV or stereo sets, home insulation, felt insulation, casebacks production, trimming.



64.16 CL



Versione V - V model

MINI	64.16 CL	4 ÷ 16 5/32" ÷ 5/8"	360	4 ÷ 6 60 ÷ 90	1,10 2,43	0,13 0,00459	350 x 43 x 148 13-13/16" x 1-11/16" x 5-13/16"
	64.16 CLV	4 ÷ 16 5/32" ÷ 5/8"	360	4 ÷ 6 60 ÷ 90	1,15 2,54	0,13 0,00459	350 x 43 x 148 13-13/16" x 1-11/16" x 5-13/16"

SPECIFICHE SPECIFICATIONS

Punti per barretta 167
Staples per strip 167

Finitura zincato
Finishing galvanized

A richiesta inox
On request stainless steel



64.16 CLT

MINI	64.16 CLT	4 ÷ 16 5/32" ÷ 5/8"	340	4 ÷ 6 60 ÷ 90	1,10 2,43	0,13 0,00459	362 x 43 x 148 14-1/4" x 1-11/16" x 5-13/16"
------	-----------	------------------------	-----	------------------	--------------	-----------------	---

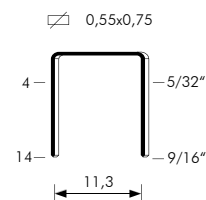

Gauge: 23
Crown: .492" (1/2")

GRAFFE LEGGERE
FINE WIRE STAPLES

62

Serie chiodine Tool series	modello	misure impiegabili (mm)	capacità caricatore (n.punti)	pressione (kg/cm ²)	peso (kg)	consumo aria (litri/colpo)	dimensioni (mm - L x W x H)
	model	applicable sizes (inch)	magazine capacity (pieces)	pressure (PSI)	weight (lbs)	air consumption (ft ³ /cycle)	dimensions (inch - L x W x H)



62.16

UTILIZZI
APPLICATIONS

Tappezzeria, produzione di mobili, cornici, calzature, fodere, set TV o stereo, isolamento delle case, isolamento in feltro, produzione di dorsi di casse, finiture interne in legno.

Upholstery, furniture, picture frames, shoe making, dust covers, TV or stereo sets, home insulation, felt insulation, casebacks production, trimming.

MINI	62.16	4 ÷ 16 5/32" + 5/8"	185	4 ÷ 6 60 ÷ 90	0,90 1,98	0,13 0,00459	216 x 43 x 148 8-1/2" x 1-11/16" x 5-13/16"
------	-------	------------------------	-----	------------------	--------------	-----------------	--

SPECIFICHE
SPECIFICATIONS

Punti per barretta 167
Staples per strip 167

Finitura zincato
Finishing galvanized

A richiesta inox
On request stainless steel



62.16 CLV

MINI	62.16 CLV	4 ÷ 16 5/32" + 5/8"	360	4 ÷ 6 60 ÷ 90	1,15 2,54	0,13 0,00459	350 x 43 x 148 13-13/16" x 1-11/16" x 5-13/16"
------	-----------	------------------------	-----	------------------	--------------	-----------------	---

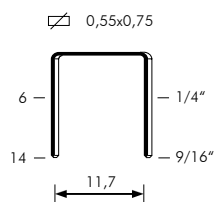

Gauge: 23
Crown: .500" (1/2")

Serie chiodatrice E.O. SERIES	modello	misure impiegabili (mm)	capacità caricatore (n.punti)	pressione (kg/cm ²)	peso (kg)	consumo aria (litri/colpo)	dimensioni (mm - L x W x H)
	model	applicabile sizes (inch)	magazine capacity (pieces)	pressure (PSI)	weight (lbs)	air consumption (l ³ /cycle)	dimensions (inch - L x W x H)

GRAFFE LEGGERE FINE WIRE STAPLES

99

UTILIZZI APPLICATIONS

Produzione di calzature, oggetti in legno, sedie a sdraio.

Shoe making, wooden articles and deckchairs.



99.16

MINI	99.16	4 ÷ 16	130	4 ÷ 6	0,90	0,13	216 x 43 x 148
		5/32" ÷ 5/8"	130	60 ÷ 90	1,98	0,00459	8-1/2" x 1-11/16" x 5-13/16"

SPECIFICHE SPECIFICATIONS

Punti per barretta 125
Staples per strip 125

Finitura zincato
Finishing galvanized

0,55x1,00

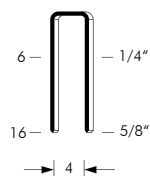

Gauge: 21
Crown: .200" (7/32")

GRAFFE LEGGERE
FINE WIRE STAPLES

4097

Serie chiodatrice Tool series	modello	misure impiegabili (mm)	capacità caricatore (n.punti)	pressione (kg/cm ²)	peso (kg)	consumo aria (litri/colpo)	dimensioni (mm - L x W x H)
	model	applicable sizes (inch)	magazine capacity (pieces)	pressure (PSI)	weight (lbs)	air consumption (ft ³ /cycle)	dimensions (inch - L x W x H)

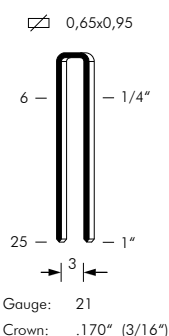

4097.16



Versione SL - SL model

MINI	4097.16	4 ÷ 16	135	4 ÷ 6	0,90	0,13	216 x 43 x 148
		5/32" ÷ 5/8"	135	60 ÷ 90	1,98	0,00459	8-1/2" x 1-11/16" x 5-13/16"
	4097.16 SL	4 ÷ 16	135	4 ÷ 6	1,00	0,18	216 x 43 x 198
		5/32" ÷ 5/8"	135	60 ÷ 90	2,20	0,00636	8-1/2" x 1-11/16" x 7-13/16"

40

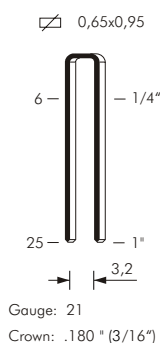

4097.16 CLM

MINI	4097.16 CLM	8 ÷ 16	270	4 ÷ 6	1,07	0,13	362 x 43 x 148
		5/16" ÷ 5/8"	270	60 ÷ 90	2,36	0,00459	14-1/4" x 1-11/16" x 5-13/16"

UTILIZZI APPLICATIONS

Produzione di calzature, oggetti in legno per la casa, ombrelli e spazzole, intelaiatura e finitura mobili, produzione mobili in rattan, mobiletti, cornici per quadri e specchi, perlinati, intelaiature per porte, produzione di bobine per cavi e gabbie.

Shoemaking, production of home wooden articles, brushes, umbrellas, furniture framing and finishing, production of rattan furniture, cabinets, picture and mirror frames, beading, door framing, production of bobbins and crates.

SPECIFICHE SPECIFICATIONS

Punti per barretta 125
Staples per strip 125

Finitura zincato
Finishing galvanvanized

A richiesta inox
On request stainless steel



4097.16 CLT

MINI	4097.16 CLT	4 ÷ 16	270	4 ÷ 6	1,07	0,13	362 x 43 x 148
		5/32" ÷ 5/8"	270	60 ÷ 90	2,36	0,00459	14-1/4" x 1-11/16" x 5-13/16"

Serie chiodatrice EOL SERIES	modello	misure impiegabili (mm)	capacità caricatore (n.punti)	pressione (kg/cm ²)	peso (kg)	consumo aria (litri/colpo)	dimensioni (mm - L x W x H)
	model	applicable sizes (inch)	magazine capacity (pieces)	pressure (PSI)	weight (lbs)	air consumption (ft ³ /cycle)	dimensions (inch - L x W x H)

GRAFFE LEGGERE
FINE WIRE STAPLES

4097



4097.25

210	4097.25	12 ÷ 25	135	5 ÷ 6,5	1,15	0,31	219 x 50 x 211
		1/2" ÷ 1"	135	70 ÷ 95	2,54	0,01095	8-5/8" x 2" x 8-5/16"

0,65x0,95

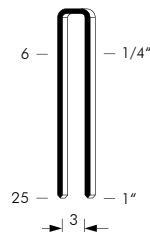

Gauge: 21
Crown: .170" (3/16")



4097.25 SL

210	4097.25 SL	12 ÷ 25	135	5 ÷ 6,5	1,20	0,41	219 x 50 x 245
		1/2" ÷ 1"	135	70 ÷ 95	2,65	0,01448	8-5/8" x 2" x 9-5/16"

0,65x0,95

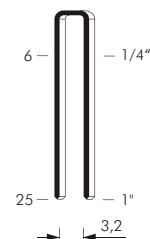

Gauge: 21
Crown: .180" (3/16")

40

UTILIZZI APPLICATIONS

Produzione di calzature, oggetti in legno per la casa, ombrelli e spazzole, intelaiatura e finitura mobili, produzione mobili in rattan, mobiletti, cornici per quadri e specchi, perlinati, intelaiature per porte, produzione di bobine per cavi e gabbie.

Shoemaking, production of home wooden articles, brushes, umbrellas, furniture framing and finishing, production of rattan furniture, cabinets, picture and mirror frames, beading, door framing, production of bobbins and crates.

SPECIFICHE SPECIFICATIONS

Punti per barretta 125
Staples per strip 125

Finitura zincato
Finishing galvanized

A richiesta inox
On request stainless steel



4097.25 CLT

210	4097.25 CLT	12 ÷ 25	270	5 ÷ 6,5	1,15	0,31	380 x 50 x 211
		1/2" ÷ 1"	270	70 ÷ 95	2,53	0,01095	15" x 2" x 8-5/16"

GRAFFE LEGGERE
FINE WIRE STAPLES

98

Serie chiodatrice Tool series	modello	misure impiegabili (mm)	capacità caricatore (n.punti)	pressione (kg/cm ²)	peso (kg)	consumo aria (litri/colpo)	dimensioni (mm - L x W x H)
	model	applicable sizes (inch)	magazine capacity (pieces)	pressure (PSI)	weight (lbs)	air consumption (ft ³ /cycle)	dimensions (inch - L x W x H)



98.16

MINI	98.16	4 ÷ 16 5/32" ÷ 5/8"	145	4 ÷ 6 60 ÷ 90	0,90 1,98	0,13 0,00459	216 x 43 x 148 8-1/2" x 1-11/16" x 5-13/16"
------	-------	------------------------	-----	------------------	--------------	-----------------	--

UTILIZZI
APPLICATIONS

Tappezzeria, mobiletti per scarpe, mobili per il bagno, sets TV e altoparlanti.

Upholstery, manufacture of shoe cabinets and bathroom furniture, TV & stereo set production.

SPECIFICHE
SPECIFICATIONS

Punti per barretta 125
Staples per strip 125

Finitura zincato
Finishing galvanized

A richiesta stanox
On request liquor finish



98.25

210	98.25	12 ÷ 25 1/2" ÷ 1"	145	5 ÷ 6,5 70 ÷ 95	1,10 2,43	0,31 0,01095	219 x 50 x 211 8-5/8" x 2" x 8-5/16"
-----	-------	----------------------	-----	--------------------	--------------	-----------------	---

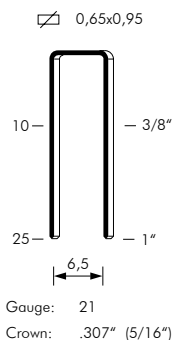

Serie chiodatrice E.O. 38163	modello	misure impiegabili (mm)	capacità caricatore (n.punti)	pressione (kg/cm ²)	peso (kg)	consumo aria (litri/colpo)	dimensioni (mm - L x W x H)
	model	applicable sizes (inch)	magazine capacity (pieces)	pressure (PSI)	weight (lbs)	air consumption (ft ³ /cycle)	dimensions (inch - L x W x H)

GRAFFE LEGGERE
FINE WIRE STAPLES

84



84.16



Versione SL - SL model



Versione V - V model

MINI	84.16	4 ÷ 16	145	4 ÷ 6	0,90	0,13	216 x 43 x 148
		5/32" ÷ 5/8"	145	60 ÷ 90	1,98	0,00459	8-1/2" x 1-11/16" x 5-13/16"
	84.16 SL	4 ÷ 16	145	4 ÷ 6	1,00	0,18	216 x 43 x 198
		5/32" ÷ 5/8"	145	60 ÷ 90	2,20	0,00636	8-1/2" x 1-11/16" x 7-13/16"
	84.16 V	4 ÷ 16	145	4 ÷ 6	0,95	0,13	216 x 43 x 148
		5/32" ÷ 5/8"	145	60 ÷ 90	2,09	0,00459	8-1/2" x 1-11/16" x 5-13/16"

UTILIZZI APPLICATIONS

Settore calzaturiero, produzione e finitura mobili, cornici, dorsi di armadietti, sedili per barche (inox), oggettistica in legno, biliardi e video games, set stereo e TV, gabbie di legno, parasoli, interni di auto in legno e vinile, base per tappezzeria, costruzione di porte e finestre, isolamento in feltro, allestimenti fieristici.

Shoemaking, production and finishing of furniture, picture frames, cabinet backs, boat seating (stainless steel), wooden articles, video games and billiards, TV & stereo sets, wooden crates, sunshades, automotive vinyl and interior trim, pre-upholstery, manufacturing of doors and windows, felt insulation, exhibition fitting-out.

SPECIFICHE SPECIFICATIONS

Punti per barretta 139/125
Staples per strip 139/125

Finitura stanox
Finishing liquor finish

A richiesta zincato, inox
On request galvanized, stainless steel

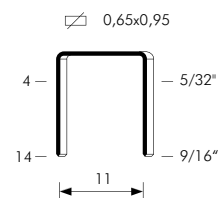

Gauge: 21
Crown: .480" (1/2")

GRAFFE LEGGERE
FINE WIRE STAPLES

80

Serie chiodatrice Tool series	modello	misure impiegabili (mm)	capacità caricatore (n.punti)	pressione (kg/cm ²)	peso (kg)	consumo aria (litri/colpo)	dimensioni (mm - L x W x H)
	model	applicable sizes (inch)	magazine capacity (pieces)	pressure (PSI)	weight (lbs)	air consumption (ft ³ /cycle)	dimensions (inch - L x W x H)

UTILIZZI
APPLICATIONS

Settore calzaturiero, produzione e finitura mobili, cornici, dorsi di armadietti, sedili per barche (inox), oggettistica in legno, biliardi e video games, set stereo e TV, gabbie di legno, parasoli, interni di auto in legno e vinile, base per tappezzeria, costruzione di porte e finestre, isolamento in feltro, allestimenti fieristici, cucitura di sacchetti.

Shoemaking, production and finishing of furniture, picture frames, cabinet backs, boat seating (stainless steel), wooden articles, video games and billiards, TV & stereo sets, wooden crates, sunshades, automotive vinyl and interior trim, pre-upholstery, manufacturing of doors and windows, felt insulation, exhibition fitting-out, manufacturing of paperbags.

SPECIFICHE
SPECIFICATIONS

Punti per barretta 139/125
Staples per strip 139/125

Finitura stanox
Finishing liquor finish

A richiesta zincato, inox, alluminio, verniciato

On request galvanized, stainless steel, aluminium, painted



80.16



Versione S - S model



Versione SL - SL model



Versione V - V model

MINI	80.16	4 ÷ 16 5/32"÷ 5/8"	145	4 ÷ 6 60 ÷ 90	0,90 1,98	0,13 0,00459	216 x 43 x 148 8-1/2" x 1-11/16" x 5-13/16"
	80.16 SL	4 ÷ 16 5/32"÷ 5/8"	145	4 ÷ 6 60 ÷ 90	1,00 2,20	0,18 0,00636	216 x 43 x 198 8-1/2" x 1-11/16" x 7-13/16"
80.16 V	4 ÷ 16 5/32"÷ 5/8"	145	4 ÷ 6 60 ÷ 90	0,95 2,09	0,13 0,00459	216 x 43 x 148 8-1/2" x 1-11/16" x 5-13/16"	
	80.16 S	4 ÷ 16 5/32"÷ 5/8"	145	4 ÷ 6 60 ÷ 90	0,90 1,98	0,13 0,00459	216 x 43 x 153 8-1/2" x 1-11/16" x 6-1/16"



80.16 CL



Versione V - V model

MINI	80.16 CL	4 ÷ 16 5/32"÷ 5/8"	280	4 ÷ 6 60 ÷ 90	1,10 2,43	0,13 0,00459	350 x 43 x 148 13-13/16" x 1-11/16" x 5-13/16"
	80.16 CLV	4 ÷ 16 5/32"÷ 5/8"	280	4 ÷ 6 60 ÷ 90	1,15 2,54	0,13 0,00459	350 x 43 x 148 13-13/16" x 1-11/16" x 5-13/16"

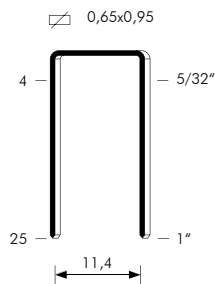

Gauge: 21
Crown: .500" (1/2")



80.16 CLT

MINI	80.16 CLT	4 ÷ 16 5/32"÷ 5/8"	270	4 ÷ 6 60 ÷ 90	1,10 2,43	0,13 0,00459	362 x 43 x 148 14-1/4" x 1-11/16" x 5-13/16"
------	-----------	-----------------------	-----	------------------	--------------	-----------------	---

Serie chiodatrice E.O. SERIES	modello	misure impiegabili (mm)	capacità caricatore (n.punti)	pressione (kg/cm ²)	peso (kg)	consumo aria (litri/colpo)	dimensioni (mm - L x W x H)
	model	applicable sizes (inch)	magazine capacity (pieces)	pressure (PSI)	weight (lbs)	air consumption (l/cycle)	dimensions (inch - L x W x H)

GRAFFE LEGGERE
FINE WIRE STAPLES

80



80.16 RB

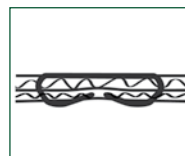

MINI	80.16 RB	6 ÷ 16 1/4" ÷ 5/8"	145	4 ÷ 6 60 ÷ 90	1,10 2,43	0,13 0,00459	216 x 43 x 168 8-1/2" x 1-11/16" x 6-5/8"
------	----------	-----------------------	-----	------------------	--------------	-----------------	--

UTILIZZI APPLICATIONS

Settore calzaturiero, produzione e finitura mobili, cornici, dorsi di armadietti, sedili per barche (inox), oggettistica in legno, biliardi e video games, set stereo e TV, gabbie di legno, parasoli, interni di auto in legno e vinile, base per tappezzeria, costruzione di porte e finestre, isolamento in feltro, allestimenti fieristici, cucitura di sacchetti.

Shoemaking, production and finishing of furniture, picture frames, cabinet backs, boat seating (stainless steel), wooden articles, video games and billiards, TV & stereo sets, wooden crates, sunshades, automotive vinyl and interior trim, pre-upholstery, manufacturing of doors and windows, felt insulation, exhibition fitting-out, manufacturing of paperbags.



80.16 OC

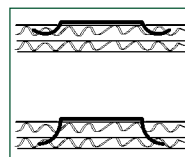

MINI	80.16 OC	10 ÷ 16 3/8" ÷ 5/8"	145	5 ÷ 6,5 70 ÷ 95	0,90 1,98	0,13 0,00459	216 x 43 x 149 8-1/2" x 1-11/16" x 5-7/8"
------	----------	------------------------	-----	--------------------	--------------	-----------------	--

SPECIFICHE SPECIFICATIONS

Punti per barretta 139/125
Staples per strip 139/125

Finitura stanox
Finishing liquor finish

A richiesta zincato, inox,
alluminio,
verniciato

On request galvanized,
stainless steel,
aluminium,
painted



80.25

210	80.25	12 ÷ 25 1/2" ÷ 1"	145	5 ÷ 6,5 70 ÷ 95	1,10 2,43	0,31 0,01095	219 x 50 x 211 8-5/8" x 2" x 8-5/16"
-----	-------	----------------------	-----	--------------------	--------------	-----------------	---

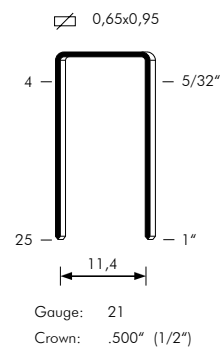

GRAFFE LEGGERE
FINE WIRE STAPLES

50

Serie chiodatrice Dial series	modello	misure impieghiabili (mm)	capacità caricatore (n.punti)	pressione (kg/cm ²)	peso (kg)	consumo aria (litri/colpo)	dimensioni (mm - L x W x H)
	model	applicable sizes (inch)	magazine capacity (pieces)	pressure (PSI)	weight (lbs)	air consumption (ft ³ /cycle)	dimensions (inch - L x W x H)

UTILIZZI
APPLICATIONS

Tapezzeria, manifattura letti, intelaiature, tappezzeria murale, isolamento nelle case, assemblaggi con legno tenero.

Upholstery, bedding, framing, wall wallpaper, home insulation, light wood assembly.



50.16



Versione SL - SL model



Versione S - S model

MINI	50.16	4 ÷ 16 5/32" ÷ 5/8"	105	4 ÷ 6 60 ÷ 90	0,90 1,98	0,13 0,00459	216 x 43 x 148 8-1/2" x 1-11/16" x 5-13/16"
	50.16 SL	4 ÷ 16 5/32" ÷ 5/8"	105	4 ÷ 6 60 ÷ 90	1,00 2,20	0,18 0,00636	216 x 43 x 198 8-1/2" x 1-11/16" x 7-13/16"
50.16 S	4 ÷ 16 5/32" ÷ 5/8"	105	4 ÷ 6 60 ÷ 90	0,90 1,98	0,13 0,00459	216 x 43 x 153 8-1/2" x 1-11/16" x 6-1/16"	

SPECIFICHE
SPECIFICATIONS

Punti per barretta 84
Staples per strip 84

Finitura zincato
Finishing galvanized

A richiesta inox,
DP (punte divergenti)

On request stainless steel,
DP (divergent point)



50.16 CL



Versione S - S model



Versione V - V model

MINI	50.16 CL	4 ÷ 16 5/32" ÷ 5/8"	210	4 ÷ 6 60 ÷ 90	1,10 2,43	0,13 0,00459	350 x 43 x 148 13-13/16" x 1-11/16" x 5-13/16"
	50.16 CLV	4 ÷ 16 5/32" ÷ 5/8"	210	4 ÷ 6 60 ÷ 90	1,15 2,54	0,13 0,00459	350 x 43 x 148 13-13/16" x 1-11/16" x 5-13/16"
50.16 SCL	4 ÷ 16 5/32" ÷ 5/8"	210	4 ÷ 6 60 ÷ 90	1,10 2,43	0,13 0,00459	350 x 43 x 153 13-13/16" x 1-11/16" x 6-1/16"	



50.16 RB

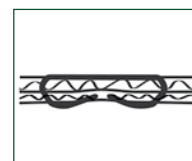

MINI	50.16 RB	6 ÷ 16 1/4" ÷ 5/8"	105	4 ÷ 6 60 ÷ 90	1,10 2,43	0,13 0,00459	216 x 43 x 168 8/1-2" x 1-11/16" x 6-5/8"
------	----------	-----------------------	-----	------------------	--------------	-----------------	--

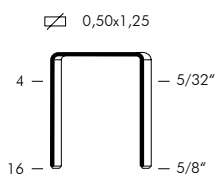

Gauge: 20
Crown: .484" (1/2")



50.16 OC

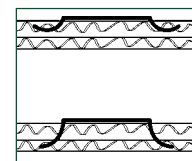

MINI	50.16 OC	10 ÷ 16 3/8" ÷ 5/8"	105	5 ÷ 6,5 70 ÷ 95	0,90 1,98	0,13 0,00459	216 x 43 x 149 8/1-2" x 1-11/16" x 5-7/8"
------	----------	------------------------	-----	--------------------	--------------	-----------------	--

Serie chiodatrice EOL 38183	modello	misure impiegabili (mm)	capacità caricatore (n.punti)	pressione (kg/cm ²)	peso (kg)	consumo aria (litri/colpo)	dimensioni (mm - L x W x H)
	model	applicable sizes (inch)	magazine capacity (pieces)	pressure (PSI)	weight (lbs)	air consumption (ft ³ /cycle)	dimensions (inch - L x W x H)

GRAFFE LEGGERE
FINE WIRE STAPLES

T50



T50.16

MINI	T50.16	4 ÷ 16 5/32" ÷ 5/8"	105	4 ÷ 6 60 ÷ 90	0,90 1,98	0,13 0,00459	216 x 43 x 148 8-1/2" x 1-11/16" x 5-13/16"
------	--------	------------------------	-----	------------------	--------------	-----------------	--

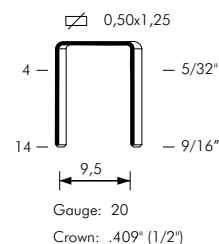

SPECIFICHE SPECIFICATIONS

Punti per barretta Staples per strip	84 84
Finitura Finishing	zincato galvanized
A richiesta On request	alluminio aluminium

UTILIZZI APPLICATIONS

Tappezzeria, manifattura
letti, intelaiature, tappezzeria
murale, isolamento nelle case,
assemblaggi con legno tenero.

Upholstery, bedding, framing,
wall wallpaper, home insulation,
light wood assembly.



65.16

MINI	65.16	4 ÷ 16 5/32" ÷ 5/8"	105	4 ÷ 6 60 ÷ 90	0,90 1,98	0,13 0,00459	216 x 43 x 148 8-1/2" x 1-11/16" x 5-13/16"
------	-------	------------------------	-----	------------------	--------------	-----------------	--

65

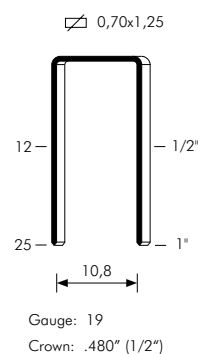

SPECIFICHE SPECIFICATIONS

Punti per barretta Staples per strip	84 84
Finitura Finishing	stanox liquor finish
A richiesta On request	zincato galvanized

UTILIZZI APPLICATIONS

Telaio mobili, assemblaggio
mobilietti.

Furniture framing, cabinet
assembly.



65.25

210	65.25	12 ÷ 25 1/2" ÷ 1"	105	5 ÷ 6,5 70 ÷ 95	1,15 2,54	0,31 0,01095	219 x 50 x 211 8-5/8" x 2" x 8-5/16"
-----	-------	----------------------	-----	--------------------	--------------	-----------------	---

GRAFFE LEGGERE
FINE WIRE STAPLES

88

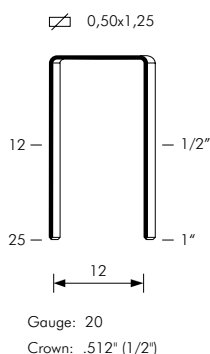

SPECIFICHE
SPECIFICATIONS

Punti per barretta **84**
Staples per strip **84**

Finitura **zincato**
Finishing **galvanized**

Serie chiodatrice Tool series	modello	misure impiegabili (mm)	capacità caricatore (n.punti)	pressione (kg/cm ²)	peso (kg)	consumo aria (litri/colpo)	dimensioni (mm - L x W x H)
	model	applicable sizes (inch)	magazine capacity (pieces)	pressure (PSI)	weight (lbs)	air consumption (ft ³ /cycle)	dimensions (inch - L x W x H)



210	PL 88	12 ÷ 25	200	5 ÷ 6,5	2,15	0,25	360 x 70 x 310
		1/2" ÷ 1"	200	70 ÷ 95	4,74	0,00883	14-3/16" x 2-3/4" x 12-3/16"

GRAFFE MEDIE
MEDIUM WIRE STAPLES

110

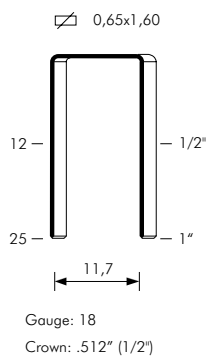

SPECIFICHE
SPECIFICATIONS

Punti per barretta **75**
Staples per strip **75**

Finitura **stanox**
Finishing **liquor finish**

UTILIZZI
APPLICATIONS

Produzione materassi,
chiusura scatole cartone,
produzione imballi cartone,
fissaggio di gommapiuma.

Production of mattresses,
carton closing, fastening
of cardboard boxes,
fastening of foam-rubber



MINI	110.16 RF	12 ÷ 16	86	4,5 ÷ 6	1,20	0,13	216 x 43 x 173
		1/2" ÷ 5/8"	86	65 ÷ 90	2,64	0,00459	8-1/2" x 1-11/16" x 6-13/16"



210	PL 110	12 ÷ 25	160	5 ÷ 6,5	2,15	0,25	360 x 70 x 310
		1/2" ÷ 1"	160	70 ÷ 95	4,74	0,00883	14-3/16" x 2-3/4" x 12-3/16"
	PL 110 LJ	12 ÷ 25	160	5 ÷ 6,5	2,65	0,25	360 x 70 x 330
		1/2" ÷ 1"	160	70 ÷ 95	5,84	0,00883	14-3/16" x 2-3/4" x 13"

Serie: chiodatrice D.O. SERIES	modello	misure impiegabili (mm)	capacità caricatore (n.punti)	pressione (kg/cm ²)	peso (kg)	consumo aria (litri/colpo)	dimensioni (mm - L x W x H)
	model	applicable sizes (inch)	magazine capacity (pieces)	pressure (PSI)	weight (lbs)	air consumption (ft ³ /cycle)	dimensions (inch - L x W x H)

GRAFFE MEDIE
MEDIUM WIRE STAPLES

SG44



SG44.25



Versione D - D model

210	SG44.25	9 ÷ 25	100	5 ÷ 7	1,10	0,31	219 x 50 x 211
		3/8" ÷ 1"	100	70 ÷ 100	2,43	0,01095	8-5/8" x 2" x 8-5/16"
	SG44.25 D	12 ÷ 25	100	5 ÷ 7	1,20	0,31	219 x 50 x 224
		1/2" ÷ 1"	100	70 ÷ 100	2,64	0,01095	8-5/8" x 2" x 8-13/16"

UTILIZZI APPLICATIONS

Assemblaggio di mobili e armadietti, costruzione di telai per porte e finestre, finiture interne in legno, cornicioni, impermeabilizzazioni e isolamento case, pavimenti in legno duro, rivestimenti in vinile e alluminio, fissaggio attacco per molle in tappezzeria, produzione di insegne in legno, cassetti, dorsi di casse e griglie.

Furniture and cabinets assembly, door and window casings, trimming, moldings, decking and home insulation, hardwood floors, vinyl and aluminium siding, upholstery spring attachment, production of wood shingles, drawers, casebacks and lattices.



SG44.32

420	SG44.32	9 ÷ 32	115	5 ÷ 7,5	1,25	0,45	246 x 58 x 216
		3/8" ÷ 1-1/4"	115	70 ÷ 105	2,76	0,01589	9-5/8" x 2-5/16" x 8-1/2"



SG44.38



Versione A - A model

420	SG44.38	15 ÷ 40	115	5 ÷ 7,5	1,30	0,54	246 x 58 x 248
		5/8" ÷ 1-9/16"	115	70 ÷ 105	2,87	0,01906	9-5/8" x 2-5/16" x 9-3/4"
	SG44.38 A	15 ÷ 40	115	5 ÷ 7,5	1,40	0,58	246 x 58 x 274
		5/8" ÷ 1-9/16"	115	70 ÷ 105	3,09	0,0205	9-5/8" x 2-5/16" x 10-13/16"

SPECIFICHE SPECIFICATIONS

Punti per barretta 100
Staples per strip 100

Finitura lucido
Finishing bright

A richiesta zincato, inox, alluminio, DP (punte divergenti)

On request galvanized, stainless steel, aluminium, DP (divergent point)



SG44.40

710	SG44.40	20 ÷ 40	130	4,5 ÷ 7	1,80	1,00	280 x 77 x 245
		3/4" ÷ 1-9/16"	130	65 ÷ 100	3,97	0,0353	11" x 3-1/16" x 9-5/8"

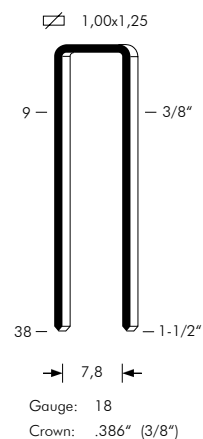

GRAFFE MEDIE
MEDIUM WIRE STAPLES

90

Serie chiodatrice Tool series	modello	misure impiegabili (mm)	capacità caricatore (n.punti)	pressione (kg/cm ²)	peso (kg)	consumo aria (litri/colpo)	dimensioni (mm - L x W x H)
	model	applicable sizes (inch)	magazine capacity (pieces)	pressure (PSI)	weight (lbs)	air consumption (ft ³ /cycle)	dimensions (inch - L x W x H)

UTILIZZI
APPLICATIONS

Assemblaggio di mobili e armadietti, costruzione di telai per porte e finestre, finiture interne in legno, cornicioni, impermeabilizzazioni e isolamento case, pavimenti in legno duro, rivestimenti in vinile e alluminio, fissaggio attacco per molle in tappezzeria, produzione di insegne in legno, cassetti, dorsi di casse e griglie.

Furniture and cabinets assembly, door and window casings, trimming, moldings, decking and home insulation, hardwood floors, vinyl and aluminium siding, upholstery spring attachment, production of wood shingles, drawers, casebacks and lattices.

SPECIFICHE
SPECIFICATIONS

Punti per barretta 100
Staples per strip 100

Finitura lucido
Finishing bright

A richiesta zincato, inox, alluminio, DP (punte divergenti)

On request galvanized, stainless steel, aluminium, DP (divergent point)



90.16

MINI	90.16	9 ÷ 15 3/8" ÷ 5/8"	100	4 ÷ 7 60 ÷ 100	0,90 1,98	0,13 0,00459	216 x 43 x 148 8-1/2" x 1-11/16" x 5-13/16"
------	-------	-----------------------	-----	-------------------	--------------	-----------------	--



90.28



90.28 CL

210	90.28	9 ÷ 28 3/8" ÷ 1-1/8"	100	5 ÷ 7,5 70 ÷ 105	1,15 2,54	0,31 0,01095	219 x 50 x 211 8-5/8" x 2" x 8-5/16"
	90.28 CL	9 ÷ 28 3/8" ÷ 1-1/8"	210	5 ÷ 7,5 70 ÷ 105	1,50 3,31	0,31 0,01095	387 x 50 x 211 15-1/4" x 2" x 8-5/16"



90.25 CLT

210	90.25 CLT	9 ÷ 25 3/8" ÷ 1"	200	5 ÷ 7,5 70 ÷ 105	1,40 3,09	0,31 0,01095	380 x 50 x 211 14-15/16" x 2" x 8-5/16"
-----	-----------	---------------------	-----	---------------------	--------------	-----------------	--

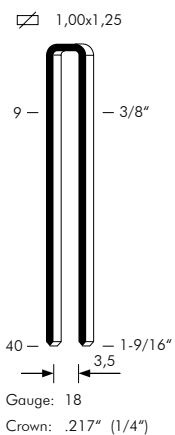

90.32



Versione R - R model

420	90.32	9 ÷ 32 3/8" ÷ 1-1/4"	115	5 ÷ 7,5 70 ÷ 105	1,25 2,76	0,45 0,01589	248 x 58 x 216 9-3/4" x 2-5/16" x 8-1/2"
	90.32 R	9 ÷ 32 3/8" ÷ 1-1/4"	115	5 ÷ 7,5 70 ÷ 105	1,25 2,76	0,45 0,01589	248 x 58 x 219 9-3/4" x 2-5/16" x 8-5/8"

Serie: chiodatrice E.O. (PAGES)	modello	misure impiegabili (mm)	capacità caricatore (n.punti)	pressione (kg/cm ²)	peso (kg)	consumo aria (litri/colpo)	dimensioni (mm - L x W x H)
	model	applicable sizes (inch)	magazine capacity (pieces)	pressure (PSI)	weight (lbs)	air consumption (ft ³ /cycle)	dimensions (inch - L x W x H)

GRAFFE MEDIE MEDIUM WIRE STAPLES

90



90.38



90.38 B



Versione A - A model

420	90.38	15 ÷ 40 5/8" ÷ 1-9/16"	115	5 ÷ 7,5 70 ÷ 105	1,30 2,87	0,54 0,01906	246 x 58 x 248 9-5/8" x 2-5/16" x 9-3/4"
	90.38 A	15 ÷ 40 5/8" ÷ 1-9/16"	115	5 ÷ 7,5 70 ÷ 105	1,40 3,09	0,58 0,0205	246 x 58 x 274 9-11/16" x 2-5/16" x 10-13/16"
	90.38 B	15 ÷ 40 5/8" ÷ 1-9/16"	105	5 ÷ 7,5 70 ÷ 105	1,50 3,31	0,54 0,01906	234 x 58 x 245 9-7/32" x 2-5/16" x 9-5/8"

UTILIZZI APPLICATIONS

Assemblaggio di mobili e armadietti, costruzione di telai per porte e finestre, finiture interne in legno, cornicioni, impermeabilizzazioni e isolamento case, pavimenti in legno duro, rivestimenti in vinile e alluminio, fissaggio attacco per molle in tappezzeria, produzione di insegne in legno, casseti, dorsi di casse e griglie.

Furniture and cabinets assembly, door and window casings, trimming, moldings, decking and home insulation, hardwood floors, vinyl and aluminium siding, upholstery spring attachment, production of wood shingles, drawers, casebacks and lattices.



90.38 CLD3



90.38 FL

420	90.38 FL	15 ÷ 40 5/8" ÷ 1-9/16"	115	5 ÷ 7,5 70 ÷ 105	1,75 3,86	0,54 0,01906	252 x 76 x 262 9-5/16" x 3" x 10-5/16"
	90.38 CLD3	15 ÷ 40 5/8" ÷ 1-9/16"	300	5 ÷ 7,5 70 ÷ 105	1,60 3,53	0,54 0,01906	480 x 58 x 241 18-7/8" x 2-5/16" x 9-1/2"

SPECIFICHE SPECIFICATIONS

Punti per barretta 100
Staples per strip 100

Finitura lucido
Finishing bright

A richiesta zincato, inox, alluminio, DP (punte divergenti)

On request galvanized, stainless steel, aluminium, DP (divergent point)



90.40



Versione NS - NS model

710	90.40	20 ÷ 40 3/4" ÷ 1-9/16"	130	4,5 ÷ 7 65 ÷ 100	1,80 3,97	1,00 0,0353	280 x 77 x 245 11" x 3-1/16" x 9-5/8"
	90.40 NS	20 ÷ 40 3/4" ÷ 1-9/16"	130	4,5 ÷ 7 65 ÷ 100	1,80 3,97	1,00 0,0353	246 x 77 x 245 11" x 3-1/16" x 9-5/8"

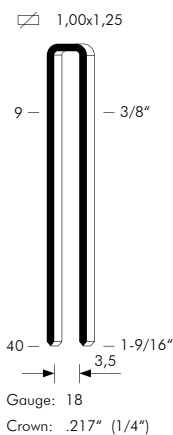

GRAFFE MEDIE
MEDIUM WIRE STAPLES

92

Serie chiodatrice Tool series	modello	misure impiegabili (mm)	capacità caricatore (n.punti)	pressione (kg/cm ²)	peso (kg)	consumo aria (litri/colpo)	dimensioni (mm - L x W x H)
	model	applicable sizes (inch)	magazine capacity (pieces)	pressure (PSI)	weight (lbs)	air consumption (ft ³ /cycle)	dimensions (inch - L x W x H)



92.16

MINI	92.16	9 ÷ 15 3/8" ÷ 5/8"	100	4 ÷ 7 60 ÷ 100	0,90 1,98	0,13 0,00459	216 x 43 x 148 8-1/2" x 1-11/16" x 5-13/16"
------	-------	-----------------------	-----	-------------------	--------------	-----------------	--

UTILIZZI
APPLICATIONS

Assemblaggio di mobili e armadietti, costruzione di telai per porte e finestre, finiture interne in legno, cornicioni, impermeabilizzazioni e isolamento case, pavimenti in legno duro, rivestimenti in vinile e alluminio, fissaggio attacco per molle in tappezzeria, produzione di insegne in legno, cassette, dorsi di casse e griglie.

Furniture and cabinets assembly, door and window casings, trimming, moldings, decking and home insulation, hardwood floors, vinyl and aluminium siding, upholstery spring attachment, production of wood shingles, drawers, casebacks and lattices.

SPECIFICHE
SPECIFICATIONS

Punti per barretta 100
Staples per strip 100

Finitura lucido
Finishing bright

A richiesta zincato, inox, alluminio, DP (punte divergenti)

On request galvanized, stainless steel, aluminium, DP (divergent point)



92.25

92.25 SL



Versione D - D model

210	92.25	9 ÷ 25 3/8" ÷ 1"	100	5 ÷ 7 70 ÷ 100	1,10 2,43	0,31 0,01095	219 x 50 x 211 8-5/8" x 2" x 8-5/16"
	92.25 D	9 ÷ 25 3/8" ÷ 1"	100	5 ÷ 7 70 ÷ 100	1,20 2,64	0,31 0,01095	219 x 50 x 215 8-5/8" x 2" x 8-7/16"
92.25 SL	9 ÷ 25 3/8" ÷ 1"	100	5 ÷ 7 70 ÷ 100	1,20 2,64	0,41 0,01448	219 x 50 x 245 8-5/8" x 2" x 9-5/8"	

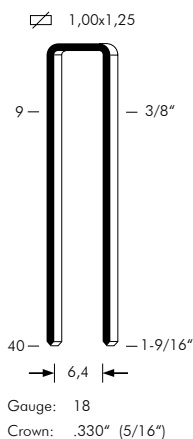

92.32

420	92.32	9 ÷ 32 3/8" ÷ 1-1/4"	115	5 ÷ 7,5 70 ÷ 105	1,25 2,76	0,45 0,01589	248 x 58 x 216 9-3/4" x 2-5/16" x 8-1/2"
-----	-------	-------------------------	-----	---------------------	--------------	-----------------	---

Serie chiodatrice EO SERIES	modello	misure impiegabili (mm)	capacità caricatore (n.punti)	pressione (kg/cm ²)	peso (kg)	consumo aria (litri/colpo)	dimensioni (mm - L x W x H)
	model	applicable sizes (inch)	magazine capacity (pieces)	pressure (PSI)	weight (lbs)	air consumption (ft ³ /cycle)	dimensions (inch - L x W x H)

GRAFFE MEDIE MEDIUM WIRE STAPLES

92



92.38



92.38 CLD3



Versione A - A model

UTILIZZI APPLICATIONS

Assemblaggio di mobili e armadietti, costruzione di telai per porte e finestre, finiture interne in legno, cornicioni, impermeabilizzazioni e isolamento case, pavimenti in legno duro, rivestimenti in vinile e alluminio, fissaggio attacco per molle in tappezzeria, produzione di insegne in legno, casseti, dorsi di casse e griglie.

Furniture and cabinets assembly, door and window casings, trimming, moldings, decking and home insulation, hardwood floors, vinyl and aluminium siding, upholstery spring attachment, production of wood shingles, drawers, casebacks and lattices.

420	92.38	15 ÷ 40 5/8" ÷ 1-9/16"	115	5 ÷ 7,5 70 ÷ 105	1,30 2,87	0,54 0,01906	246 x 58 x 248 9-5/8" x 2-5/16" x 9-3/4"
	92.38 A	15 ÷ 40 5/8" ÷ 1-9/16"	115	5 ÷ 7,5 70 ÷ 105	1,40 3,09	0,58 0,0205	246 x 58 x 274 9-11/16" x 2-5/16" x 10-13/16"
	92.38 CLD3	15 ÷ 40 5/8" ÷ 1-9/16"	300	5 ÷ 7,5 70 ÷ 105	1,90 4,19	0,54 0,01906	480 x 58 x 241 18-7/8" x 2-5/16" x 9-1/2"



92.38 B



92.38 OC

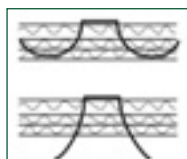

Versione OC - OC model



Versione BDA - BDA model

SPECIFICHE SPECIFICATIONS

Punti per barretta 100
Staples per strip 100

Finitura lucido
Finishing bright

A richiesta zincato, inox,
alluminio,
DP (punte
divergenti)

On request galvanized,
stainless steel,
aluminium,
DP (divergent
point)

420	92.38 B	15 ÷ 40 5/8" ÷ 1-9/16"	105	5 ÷ 7,5 70 ÷ 105	1,50 3,31	0,54 0,01906	234 x 58 x 245 9-1/4" x 2-5/16" x 9-5/8"
	92.38 BDA	15 ÷ 40 5/8" ÷ 1-9/16"	105	5 ÷ 7,5 70 ÷ 105	1,50 3,31	0,54 0,01906	234 x 58 x 245 9-1/4" x 2-5/16" x 9-5/8"
	92.38 OC	15 ÷ 40 5/8" ÷ 1-9/16"	105	5 ÷ 7,5 70 ÷ 105	1,59 3,50	0,54 0,01906	234 x 58 x 245 9-3/16" x 2-5/16" x 9-5/8"



92.40

710	92.40	20 ÷ 40 3/4" ÷ 1-9/16"	130	4,5 ÷ 7 65 ÷ 100	1,80 3,97	1,00 0,0353	280 x 77 x 245 11" x 3-1/16" x 9-5/8"
-----	-------	---------------------------	-----	---------------------	--------------	----------------	--

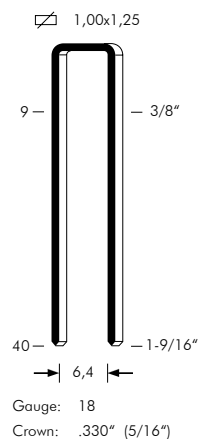

GRAFFE MEDIE
MEDIUM WIRE STAPLES

500

Serie cilindrica Tub series	modello	misure impiegabili (mm)	capacità caricatore (n.punti)	pressione (kg/cm ²)	peso (kg)	consumo aria (litri/colpo)	dimensioni (mm - L x W x H)
	model	applicable sizes (inch)	magazine capacity (pieces)	pressure (PSI)	weight (lbs)	air consumption (ft ³ /cycle)	dimensions (inch - L x W x H)

UTILIZZI
APPLICATIONS

Assemblaggio di mobili e armadietti, costruzione di telai per porte e finestre, finiture interne in legno, cornicioni, impermeabilizzazioni e isolamento case, pavimenti in legno duro, rivestimenti in vinile e alluminio, fissaggio attacco per molle in tappezzeria, produzione di insegne in legno, cassetti, dorsi di casse e griglie.

Furniture and cabinets assembly, door and window casings, trimming, moldings, decking and home insulation, hardwood floors, vinyl and aluminium siding, upholstery spring attachment, production of wood shingles, drawers, casebacks and lattices.



500.38 B

SPECIFICHE
SPECIFICATIONS

Punti per barretta 100
Staples per strip 100

Finitura lucido
Finishing bright

A richiesta zincato, inox, alluminio, DP (punte divergenti)

On request galvanized, stainless steel, aluminium, DP (divergent point)

420	500.38 B	15 ÷ 40	105	5 ÷ 7,5	1,50	0,54	234 x 58 x 245
		5/8" ÷ 1-9/16"	105	70 ÷ 105	3,30	0,01906	9-1/4" x 2-5/16" x 9-5/8"

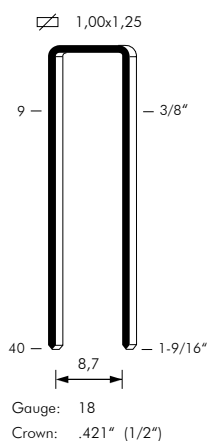

Serie chiodatrice E.O. SERIES	modello	misure impiegabili (mm)	capacità caricatore (n.punti)	pressione (kg/cm ²)	peso (kg)	consumo aria (litri/colpo)	dimensioni (mm - L x W x H)
	model	applicable sizes (inch)	magazine capacity (pieces)	pressure (PSI)	weight (lbs)	air consumption (l/cycle)	dimensions (inch - L x W x H)

GRAFFE MEDIE MEDIUM WIRE STAPLES

94



94.14



Versione S - S model

UTILIZZI APPLICATIONS

Produzione di armadietti e vetrinette, assemblaggio scaffalature, unione di elementi in legno, produzione di cassette e contenitori in legno.

Production of cabinets, racks assembling, junction of wooden elements, production of wooden cases and crates.

MINI	94.14	9 ÷ 14 3/8" ÷ 9/16"	100	4 ÷ 7 60 ÷ 100	0,90 1,98	0,13 0,00459	216 x 43 x 148 8-1/2" x 1-11/16" x 5-13/16"
	94.14 S	9 ÷ 14 3/8" ÷ 9/16"	100	4 ÷ 7 60 ÷ 100	0,95 2,09	0,13 0,00459	216 x 43 x 153 8-1/2" x 1-11/16" x 6-1/16"



94.38



Versione BDA - BDA model

SPECIFICHE SPECIFICATIONS

Punti per barretta 100
Staples per strip 100

Finitura lucido
Finishing bright

A richiesta zincato,
On request galvanizing,
aluminum

420	94.38	15 ÷ 40 5/8" ÷ 1-9/16"	105	5 ÷ 7,5 70 ÷ 105	1,50 3,31	0,54 0,01906	234 x 58 x 245 9-1/4" x 2-5/16" x 9-5/8"
	94.38 BDA	15 ÷ 40 5/8" ÷ 1-9/16"	105	5 ÷ 7,5 70 ÷ 105	1,50 3,31	0,54 0,01906	246 x 58 x 248 9-11/16" x 2-5/16" x 9-3/4"

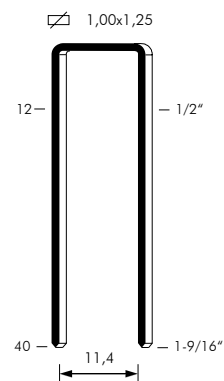

Gauge: 18
Crown: .528" (17/32")

GRAFFE PESANTI
HEAVY WIRE STAPLES

M1

Serie cilindrica Cyl. series	modello	misure impiegabili (mm)	capacità caricatore (n. punti)	pressione (kg/cm ²)	peso (kg)	consumo aria (litri/colpo)	dimensioni (mm - L x W x H)
	model	applicable sizes (inch)	magazine capacity (pieces)	pressure (PSI)	weight (lbs)	air consumption (ft ³ /cycle)	dimensions (inch - L x W x H)

UTILIZZI
APPLICATIONS

Coperture, sotto-pavimentazione, impermeabilizzazione tetti, rivestimenti, produzione finestre e cinte, intelaiatura mobili (fusti per salotti), assemblaggio mobili e mobiletti, costruzione di casse, scatole e insegne, imballaggi in legno, riparazione bancali, basamenti, finiture interne in legno.

Sheathing, subflooring, roof decking, furring, production of window units and fencing, furniture frames (living-room furniture frames), cabinets/furniture assembling, crates, boxes and shingles manufacturing, wooden packaging, pallets repair, underlayment, trimming.

SPECIFICHE
SPECIFICATIONS

Punti per barretta Staples per strip	75 75
Finitura Finishing	lucido bright
A richiesta On request	zincato galvanized



M1.40 CL



Versione NS - NS model

710	M1.40 CL	20 ÷ 40	160	5 ÷ 7,5	1,80	1,00	345 x 77 x 245
		3/4"÷ 1-9/16"	160	70 ÷ 105	3,97	0,0353	13-9/16" x 3-1/16" x 9-5/8"
710	M1.40 NS	20 ÷ 40	160	5 ÷ 7,5	1,80	1,00	345 x 77 x 245
		3/4"÷ 1-9/16"	160	70 ÷ 105	3,97	0,0353	13-9/16" x 3-1/16" x 9-5/8"



M1.65 SB

820	M1.65 SB	20 ÷ 65	145	5 ÷ 7,5	2,10	1,40	355 x 98 x 282
		3/4"÷ 2-9/16"	145	70 ÷ 105	4,63	0,04940	14" x 3-7/8" x 11-1/8"

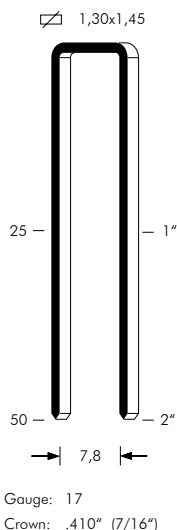

Serie: Modulare E.O. SERIES	modello	misure impiegabili (mm)	capacità caricatore (n.punti)	pressione (kg/cm ²)	peso (kg)	consumo aria (litri/colpo)	dimensioni (mm - L x W x H)
	model	applicable sizes (inch)	magazine capacity (pieces)	pressure (PSI)	weight (lbs)	air consumption (ft ³ /cycle)	dimensions (inch - L x W x H)

GRAFFE PESANTI HEAVY WIRE STAPLES

M2



M2.38 B

420	M2.38 B	15 ÷ 40	80	5 ÷ 7,5	1,50	0,54	234 x 58 x 245
		5/8" ÷ 1-9/16"	80	70 ÷ 105	3,30	0,01906	9-7/32" x 2-5/16" x 9-5/8"



M2.38 CL



Versione NS - NS model



Versione NO-SAG
NO-SAG model

710	M2.38 CL	20 ÷ 40	145	5 ÷ 7,5	1,80	1,00	345 x 77 x 245
		3/4" ÷ 1-9/16"	145	70 ÷ 105	3,97	0,0353	13-9/16" x 3-1/16" x 9-5/8"
	M2.38 NS	20 ÷ 40	145	5 ÷ 7,5	1,80	1,00	345 x 77 x 245
		3/4" ÷ 1-9/16"	145	70 ÷ 105	3,97	0,0353	13-9/16" x 3-1/16" x 9-5/8"
	M2.38 NO-SAG	20 ÷ 40	145	5 ÷ 7,5	1,80	1,00	345 x 77 x 245
		3/4" ÷ 1-9/16"	145	70 ÷ 105	3,97	0,0353	13-9/16" x 3-1/16" x 9-5/8"

UTILIZZI APPLICATIONS

Coperture, sotto-pavimentazione, impermeabilizzazione tetti, rivestimenti, produzione finestre e cinte, intelaiatura mobili (fusti per salotti), assemblaggio mobili e mobiletti, costruzione di casse, scatole e insegne, imballaggi in legno, riparazione bancali, basamenti, finiture interne in legno.

Sheathing, subflooring, roof decking, furring, production of window units and fencing, furniture frames (living-room furniture frames), cabinets/furniture assembling, crates, boxes and shingles manufacturing, wooden packaging, pallets repair, underlayment, trimming.

SPECIFICHE SPECIFICATIONS

Punti per barretta 71
Staples per strip 71

Finitura lucido
Finishing bright

A richiesta zincato, inox,
DP (punte divergenti)

On request galvanized,
stainless steel,
DP (divergent point)



M2.65 BF



Versione SB - SB model

820	M2.65 BF	20 ÷ 65	145	5 ÷ 7,5	2,10	1,40	355 x 98 x 282
		3/4" ÷ 2-9/16"	145	70 ÷ 105	4,63	0,0494	14" x 3-7/8" x 11-1/8"
	M2.65 SB	20 ÷ 65	145	5 ÷ 7,5	2,10	1,40	355 x 98 x 282
		3/4" ÷ 2-9/16"	145	70 ÷ 105	4,63	0,0494	14" x 3-7/8" x 11-1/8"

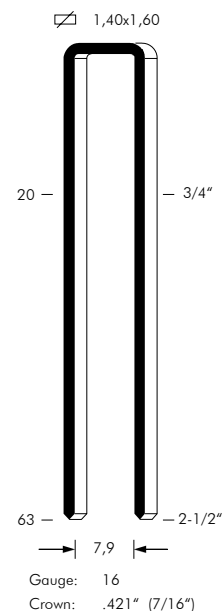

GRAFFE PESANTI
HEAVY WIRE STAPLES

700

Serie chiodatrice Tool series	modello	misure impiegabili (mm)	capacità caricatore (n.punti)	pressione (kg/cm ²)	peso (kg)	consumo aria (litri/colpo)	dimensioni (mm - L x W x H)
	model	applicable sizes (inch)	magazine capacity (pieces)	pressure (PSI)	weight (lbs)	air consumption (ft ³ /cycle)	dimensions (inch - L x W x H)



700.32 NO-SAG



Versione NO-SAG
NO-SAG model

UTILIZZI APPLICATIONS

Coperture, sotto-pavimentazione, impermeabilizzazione tetti, rivestimenti, produzione finestre e cinte, intelaiatura mobili (fusti per salotti), assemblaggio mobili e mobiletti, costruzione di casse, scatole e insegne, imballaggi in legno, riparazione bancali, basamenti, finiture interne in legno.

Sheathing, subflooring, roof decking, furring, production of window units and fencing, furniture frames (living-room furniture frames), cabinets/furniture assembling, crates, boxes and shingles manufacturing, wooden packaging, pallets repair, underlayment, trimming.

710	700.32 NO-SAG	20 ÷ 32	100	5 ÷ 7,5	1,80	1,00	280 x 77 x 245
		3/4" ÷ 1-1/4"	100	70 ÷ 105	3,97	0,0353	11" x 3-1/16" x 9-5/8"

SPECIFICHE SPECIFICATIONS

Punti per barretta 71
Staples per strip 71

Finitura lucido
Finishing bright

A richiesta zincato, inox,
DP (punte divergenti)

On request galvanized,
stainless steel,
DP (divergent point)



700.65 BF



Versione SB - SB model

820	700.65 BF	20 ÷ 65	145	5 ÷ 7,5	2,10	1,40	355 x 98 x 282
		3/4" ÷ 2-9/16"	145	70 ÷ 105	4,63	0,0494	14" x 3-7/8" x 11-1/8"
	700.65 SB	20 ÷ 65	145	5 ÷ 7,5	2,10	1,40	355 x 98 x 282
		3/4" ÷ 2-9/16"	145	70 ÷ 105	4,63	0,0494	14" x 3-7/8" x 11-1/8"

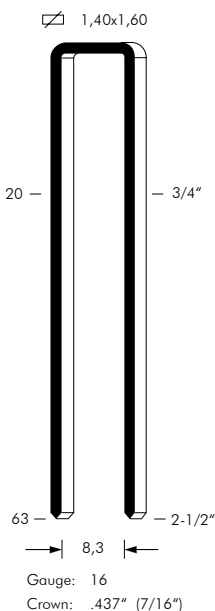

Serie chiodatrice E.O. SERIES	modello	misure impiegabili (mm)	capacità caricatore (n.punti)	pressione (kg/cm ²)	peso (kg)	consumo aria (litri/colpo)	dimensioni (mm - L x W x H)
	model	applicable sizes (inch)	magazine capacity (pieces)	pressure (PSI)	weight (lbs)	air consumption (l/cycle)	dimensions (inch - L x W x H)

GRAFFE PESANTI HEAVY WIRE STAPLES

S4



S4.65 BF



Versione SB - SB model

820	S4.65 BF	20 ÷ 65	145	5 ÷ 7,5	2,10	1,40	355 x 98 x 282
		3/4" ÷ 2-9/16"	145	70 ÷ 105	4,63	0,0494	14" x 3-7/8" x 11-1/8"
	S4.65 SB	20 ÷ 65	145	5 ÷ 7,5	2,10	1,40	355 x 98 x 282
		3/4" ÷ 2-9/16"	145	70 ÷ 105	4,63	0,0494	14" x 3-7/8" x 11-1/8"

UTILIZZI APPLICATIONS

Coperture, sotto-pavimentazione, impermeabilizzazione tetti, rivestimenti, produzione finestre e cinte, intelaiatura mobili (fusti per salotti), assemblaggio mobili e mobiletti, costruzione di casse, scatole e insegne, imballaggi in legno, riparazione bancali, basamenti, finiture interne in legno.

Sheathing, subflooring, roof decking, furring, production of window units and fencing, furniture frames (living-room furniture frames), cabinets/furniture assembling, crates, boxes and shingles manufacturing, wooden packaging, pallets repair, underlayment, trimming.

SPECIFICHE SPECIFICATIONS

Punti per barretta 71
Staples per strip 71

Finitura lucido
Finishing bright

A richiesta zincato, inox,
DP (punte divergenti)

On request galvanized,
stainless steel,
DP (divergent point)

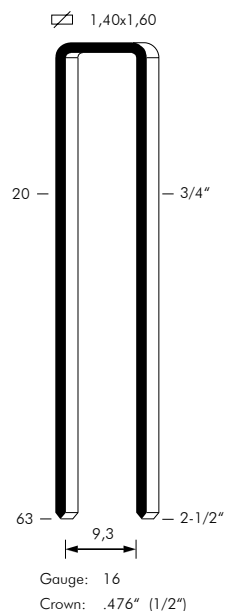

**GRAFFE PESANTI
HEAVY WIRE STAPLES**

WK

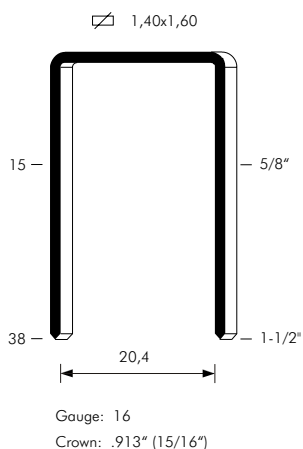

Serie chiodatrice Tool series	modello	misure impiegabili (mm)	capacità caricatore (n.punti)	pressione (kg/cm ²)	peso (kg)	consumo aria (litri/colpo)	dimensioni (mm - L x W x H)
	model	applicable sizes (inch)	magazine capacity (pieces)	pressure (PSI)	weight (lbs)	air consumption (ft ³ /cycle)	dimensions (inch - L x W x H)



WK.38



WK.38 ROOFING

710	WK.38	15 ÷ 38	150	5 ÷ 7,5	2,20	1,00	350 x 77 x 230
		5/8" ÷ 1-1/2"	150	70 ÷ 105	4,85	0,0353	13-13/16" x 3-1/16" x 9-1/16"
	WK.38 ROOFING	15 ÷ 38	150	5 ÷ 7,5	2,30	1,00	350 x 83 x 230
		5/8" ÷ 1-1/2"	150	70 ÷ 105	5,07	0,0353	13-13/16" x 3-9/32" x 9-1/16"

WP

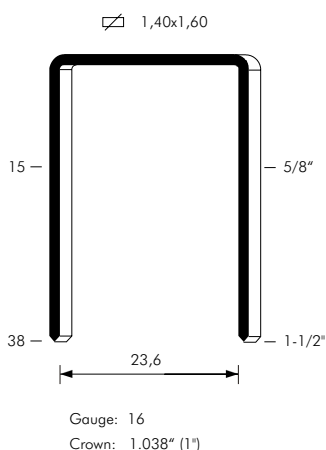

WP.38



WP.38 ROOFING

710	WP.38	15 ÷ 38	150	5 ÷ 7,5	2,20	1,00	350 x 77 x 230
		5/8" ÷ 1-1/2"	150	70 ÷ 105	4,85	0,0353	13-13/16" x 3-1/16" x 9-1/16"
	WP.38 ROOFING	15 ÷ 38	150	5 ÷ 7,5	2,30	1,00	350 x 83 x 230
		5/8" ÷ 1-1/2"	150	70 ÷ 105	5,07	0,0353	13-13/16" x 3-9/32" x 9-1/16"

**SPECIFICHE
SPECIFICATIONS**

Punti per barretta 71
Staples per strip 71

Finitura lucido
Finishing bright

A richiesta zincato, inox,
DP (punte divergenti)
On request galvanized,
stainless steel,
DP (divergent point)

**UTILIZZI
APPLICATIONS**

Costruzione di tetti (posa di tegole canadesi), intelaiatura di mobili, di porte e finestre, isolamento, installazioni con feltro, imballaggio (fissaggio di cartone su bancale), targhe e insegne.

Roofing (tiling), furniture, door and window frames, insulation, felt installations, packaging (carton to-skid), plates and shingles.

**GRAFFE PESANTI
HEAVY WIRE STAPLES**

WS

Serie: standard E.O. SERIES	modello	misure impiegabili (mm)	capacità caricatore (n.punti)	pressione (kg/cm ²)	peso (kg)	consumo aria (litri/colpo)	dimensioni (mm - L x W x H)
	model	applicable sizes (inch)	magazine capacity (pieces)	pressure (PSI)	weight (lbs)	air consumption (l/cycle)	dimensions (inch - L x W x H)



WS.38



WS.38 ROOFING

710	WS.38	15 ÷ 38	150	5 ÷ 7,5	2,20	1,00	350 x 77 x 230
			5/8" ÷ 1-1/2"	150	70 ÷ 105	4,85	0,0353
710	WS.38 ROOFING	15 ÷ 38	150	5 ÷ 7,5	2,30	1,00	350 x 83 x 230
			5/8" ÷ 1-1/2"	150	70 ÷ 105	5,07	0,03530

**UTILIZZI
APPLICATIONS**

Costruzione di tetti (posa di tegole canadesi), intelaiatura di mobili, di porte e finestre, isolamento, installazioni con feltro, imballaggio (fissaggio di cartone su bancale), targhe e insegne.

Roofing (tiling), furniture, door and window frames, insulation, felt installations, packaging (carton-to-skid), plates and shingles.



WS.38 RF



Versione RF - RF model

710	WS.38 RF	18 ÷ 38	150	5 ÷ 7,5	2,70	1,00	350 x 77 x 262
			11/16" ÷ 1-1/2"	150	70 ÷ 105	5,95	0,0353

**SPECIFICHE
SPECIFICATIONS**

Punti per barretta 71
Staples per strip 71

Finitura
Finishing lucido
bright

A richiesta
zincato, inox,
alluminio,
DP (punte
divergenti)

On request
galvanized,
stainless steel,
aluminium,
DP (divergent
point)

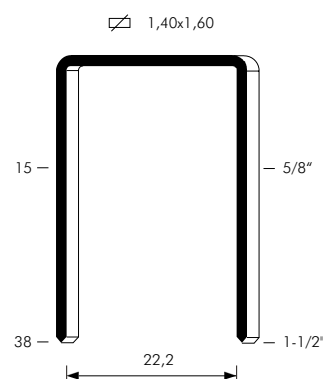

Gauge: 16
Crown: .982" (1")