



GRAFFE PER IMBALLAGGIO
CARTON CLOSING STAPLES

GRAFFE PER IMBALLAGGIO
CARTON CLOSING STAPLES

**GRAFFE PER IMBALLAGGIO
CARTON CLOSING STAPLES**

50

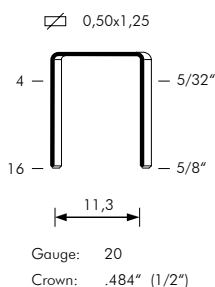

Serie chiodatrice Tool series	modello	misure impiegabili (mm)	capacità caricatore (n.punti)	pressione (kg/cm ²)	peso (kg)	consumo aria (litri/colpo)	dimensioni (mm - L x W x H)
	model	applicable sizes (inch)	magazine capacity (pieces)	pressure (PSI)	weight (lbs)	air consumption (ft ³ /cycle)	dimensions (inch - L x W x H)



**SPECIFICHE
SPECIFICATIONS**

Punti per barretta 84
Staples per strip 84

Finitura zincato
Finishing galvanized

A richiesta inox
On request stainless steel

MINI	PL50.16 LJ	10 ÷ 16 3/8" ÷ 5/8"	210	4,5 ÷ 6,5 65 ÷ 95	1,85 4,08	0,20 0,0070	350 x 64 x 249 13-3/4" x 2-1/2" x 9-13/16"
------	------------	------------------------	-----	----------------------	--------------	----------------	-----------------------------------------------

**UTILIZZI
APPLICATIONS**

Chiusura imballi di cartone.

Carton closing.

BA

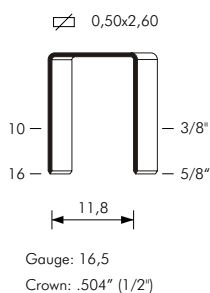

**SPECIFICHE
SPECIFICATIONS**

Punti per barretta 52
Staples per strip 52

Finitura zincato
Finishing galvanized

MINI	PLBA.16 LJ	10 ÷ 16 3/8" ÷ 5/8"	104	4,5 ÷ 6,5 65 ÷ 95	1,85 4,08	0,20 0,0070	350 x 64 x 249 13-3/4" x 2-1/2" x 9-13/16"
------	------------	------------------------	-----	----------------------	--------------	----------------	-----------------------------------------------

Serie: Modulare D.O. S.P.A.	modello	misure impiegabili (mm)	capacità caricatore (n.punti)	pressione (kg/cm ²)	peso (kg)	consumo aria (litri/colpo)	dimensioni (mm - L x W x H)
	model	applicable sizes (inch)	magazine capacity (pieces)	pressure (PSI)	weight (lbs)	air consumption (ft ³ /cycle)	dimensions (inch - L x W x H)

GRAFFE PER IMBALLAGGIO CARTON CLOSING STAPLES

32



32.18 M

CRT	32.18 M	15 ÷ 18	100	-	1,70	-	380 x 115 x 290
		5/8" ÷ 3/4"	100	-	3,74	-	15" x 4-9/16" x 11-7/16"



32.18 - 32.22

CRT	32.18	15 ÷ 18	100	5 ÷ 7	2,10	1,32	342 x 115 x 222
		5/8" ÷ 3/4"	100	70 ÷ 100	4,63	0,0466	13-7/16" x 4-1/2" x 8-3/4"
	32.22	18 ÷ 22	100	5 ÷ 7	2,10	1,32	342 x 115 x 222
		3/4" ÷ 7/8"	100	70 ÷ 100	4,63	0,0466	13-7/16" x 4-1/2" x 8-3/4"

UTILIZZI APPLICATIONS

Chiusura imballi
di cartone ondulato.

Carton closing.

SPECIFICHE SPECIFICATIONS

Punti per barretta 50
Staples per strip 50

Finitura ramato
Finishing coppered



MB.32



PB.32

CRT	MB.32	15 ÷ 22	200	-	32,70	-	760 x 550 x 1250
		5/8" ÷ 7/8"	200	-	72,09	-	30" x 21-5/8" x 49-1/4"
	PB.32	15 ÷ 22	200	5 ÷ 6	31,80	2,78	680 x 550 x 1270
		5/8" ÷ 7/8"	200	70 ÷ 90	70,10	0,09817	27-9/16" x 21-5/8" x 50"

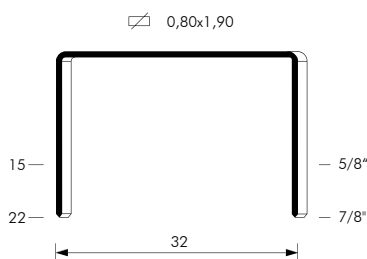

Gauge: 16,5
Crown: 1.260" (1-1/4")

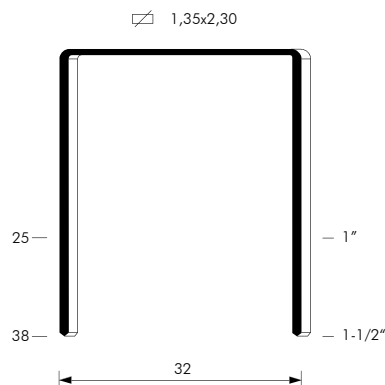

Gauge: 14
Crown: 1.260" (1-1/4")



JUMBO 32

CRT	JUMBO 32	25 ÷ 38	100	5 ÷ 7	6,00	6,70	360 x 174 x 335
		1" ÷ 1-1/2"	100	70 ÷ 100	13,23	0,23661	14-3/16" x 6-7/8" x 13-3/16"

**GRAFFE PER IMBALLAGGIO
CARTON CLOSING STAPLES**

34

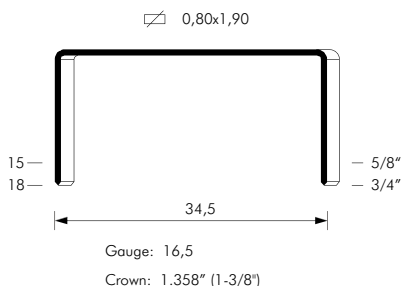

Serie chiodatrice Tool series	modello	misure impiegabili (mm)	capacità caricatore (n.punti)	pressione (kg/cm ²)	peso (kg)	consumo aria (litri/colpo)	dimensioni (mm - L x W x H)
	model	applicable sizes (inch)	magazine capacity (pieces)	pressure (PSI)	weight (lbs)	air consumption (ft ³ /cycle)	dimensions (inch - L x W x H)



CRT	34.18 M	15 ÷ 18	100	-	1,70	-	380 x 115 x 290
		5/8" ÷ 3/4"	100	-	3,74	-	15" x 4-9/16" x 11-7/16"

**UTILIZZI
APPLICATIONS**

Chiusura imballi
di cartone ondulato.

Carton closing.

**SPECIFICHE
SPECIFICATIONS**

Punti per barretta 50
Staples per strip 50

Finitura ramato
Finishing coppered



CRT	34.18	15 ÷ 18	100	5 ÷ 7	2,10	1,32	342 x 115 x 222
		5/8" ÷ 3/4"	100	70 ÷ 100	4,63	0,0466	13-7/16" x 4-1/2" x 8-3/4"

34L

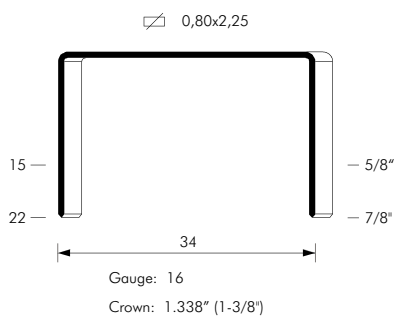

CRT	34L.18	15 ÷ 18	100	5 ÷ 7	2,10	1,32	342 x 115 x 222
		5/8" ÷ 3/4"	100	70 ÷ 100	4,63	0,0466	13-7/16" x 4-1/2" x 8-3/4"
	34L.22	18 ÷ 22	100	5 ÷ 7	2,10	1,32	342 x 115 x 222
		3/4" ÷ 7/8"	100	70 ÷ 100	4,63	0,0466	13-7/16" x 4-1/2" x 8-3/4"

Serie chiodatrice (D.O. SERIES)	modello	misure impiegabili (mm)	capacità caricatore (n.punti)	pressione (kg/cm ²)	peso (kg)	consumo aria (litri/colpo)	dimensioni (mm - L x W x H)
	model	applicable sizes (inch)	magazine capacity (pieces)	pressure (PSI)	weight (lbs)	air consumption (ft ³ /cycle)	dimensions (inch - L x W x H)

GRAFFE PER IMBALLAGGIO CARTON CLOSING STAPLES

35



35.18 M

UTILIZZI APPLICATIONS

Chiusura imballi
di cartone ondulato.

Carton closing.

CRT	35.18 M	15 ÷ 18	100	-	1,70	-	380 x 115 x 290
		5/8" ÷ 3/4"	100	-	3,74	-	15" x 4-1/2" x 11-7/16"



35.18 - 35.22

SPECIFICHE SPECIFICATIONS

Punti per barretta 50
Staples per strip 50

Finitura ramato
Finishing coppered

CRT	35.18	15 ÷ 18	100	5 ÷ 7	2,10	1,32	342 x 115 x 222
		5/8" ÷ 3/4"	100	70 ÷ 100	4,63	0,0466	13-7/16" x 4-1/2" x 8-3/4"
	35.22	18 ÷ 22	100	5 ÷ 7	2,10	1,32	342 x 115 x 222
		3/4" ÷ 7/8"	100	70 ÷ 100	4,63	0,0466	13-7/16" x 4-1/2" x 8-3/4"



MB.35



PB.35

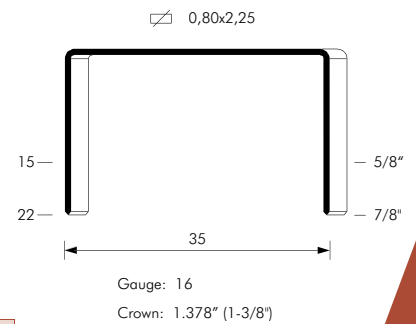

CRT	MB.35	15 ÷ 22	200	-	32,70	-	760 x 550 x 1250
		5/8" ÷ 7/8"	200	-	72,09	-	30" x 21-5/8" x 49-1/4"
	PB.35	15 ÷ 22	200	5 ÷ 6	31,80	2,78	700 x 550 x 1270
		5/8" ÷ 7/8"	200	70 ÷ 90	70,10	0,09817	27-9/16" x 21-5/8" x 50"

**GRAFFE PER IMBALLAGGIO
CARTON CLOSING STAPLES**

Roll C

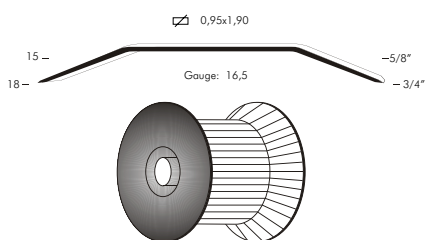

**SPECIFICHE
SPECIFICATIONS**

Punti per rotolo Staples per coil	1000 1000
Finitura Finishing	ramato coppered
A richiesta On request	5000 punti per rotolo 5000 staples per coil

**UTILIZZI
APPLICATIONS**

Chiusura imballi
di cartone ondulato.

Carton closing.

serie chiodatrice Tool series	modello	misure impiegabili (mm)	capacità caricatore (n.punti)	pressione (kg/cm ²)	peso (kg)	consumo aria (litri/colpo)	dimensioni (mm - L x W x H)
	model	applicable sizes (inch)	magazine capacity (pieces)	pressure (PSI)	weight (lbs)	air consumption (ft ³ /cycle)	dimensions (inch - L x W x H)



C.18 Roll

CRT	C.18 Roll	15 ÷ 18	1000	5 ÷ 7	2,35	1,32	237 x 115 x 222
		5/8" ÷ 3/4"	1000	70 ÷ 100	5,18	0,0466	9-5/16" x 4-1/2" x 8-3/4"

Roll 34

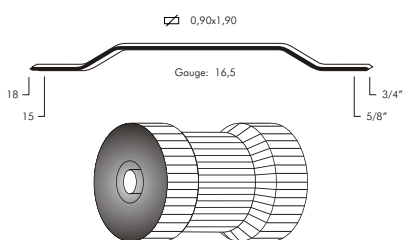

**SPECIFICHE
SPECIFICATIONS**

Punti per rotolo Staples per coil	1000 1000
Finitura Finishing	ramato coppered
A richiesta On request	4000 punti per rotolo 4000 staples per coil



34.18 Roll

CRT	34.18 Roll	15 ÷ 18	1000	5 ÷ 7	2,35	1,32	237 x 115 x 222
		5/8" ÷ 3/4"	1000	70 ÷ 100	5,18	0,0466	9-5/16" x 4-1/2" x 8-3/4"

Serie chiodatrice D.O. SERIES	modello	misure impiegabili (mm)	capacità caricatore (n.punti)	pressione (kg/cm ²)	peso (kg)	consumo aria (litri/colpo)	dimensioni (mm - L x W x H)
	model	applicable sizes (inch)	magazine capacity (pieces)	pressure (PSI)	weight (lbs)	air consumption (ft ³ /cycle)	dimensions (inch - L x W x H)

GRAFFE PER IMBALLAGGIO CARTON CLOSING STAPLES

Roll A



A.18 Roll - A.22 Roll

CRT	A.18 Roll	15 ÷ 18	1000	5 ÷ 7	2,35	1,32	237 x 115 x 222
		5/8" ÷ 3/4"	1000	70 ÷ 100	5,18	0,0466	9-5/16" x 4-1/2" x 8-3/4"
	A.22 Roll	18 ÷ 22	1000	5 ÷ 7	2,35	1,32	237 x 115 x 222
		3/4" ÷ 7/8"	1000	70 ÷ 100	5,18	0,0466	9-5/16" x 4-1/2" x 8-3/4"

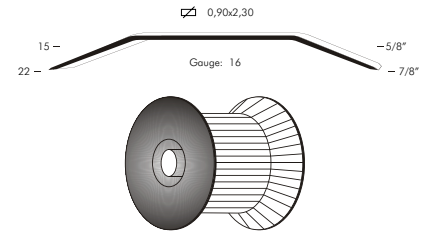

SPECIFICHE SPECIFICATIONS

Punti per rotolo Staples per coil	1000 1000
Finitura Finishing	ramato coppered
A richiesta On request	5000 punti per rotolo 5000 staples per coil

UTILIZZI APPLICATIONS

Chiusura imballi
di cartone ondulato.

Carton closing.



D.18 Roll

CRT	D.18 Roll	15 ÷ 18	1000	5 ÷ 7	2,35	1,32	237 x 115 x 222
		5/8" ÷ 3/4"	1000	70 ÷ 100	5,18	0,0466	9-5/16" x 4-1/2" x 8-3/4"

Roll D

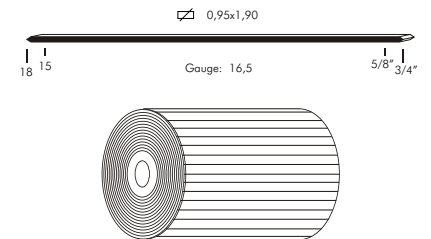

SPECIFICHE SPECIFICATIONS

Punti per rotolo Staples per coil	1000 1000
Finitura Finishing	ramato coppered
A richiesta On request	5000 punti per rotolo 5000 staples per coil